

Stainless Steel Pressure Filter Holders

KST 90 and KST 142

Sterlitech large stainless steel filter holders with reservoirs are ideal for sterilizing and ultra-cleaning as well as for flow decay tests for pilot studies.

These reservoirs are available in 304 or 316 stainless steel, for both 90 mm and 142 mm filter holders.

Model	KST 90	KST 142
304 SS	361600	302300
316 SS	361700	302400



SPECIFICATIONS

Materials:	Type 204 or 316 Stainless Steel	
Body	PTFE (Teflon) coated photoetched Stainless	
Support screen	Steel Silicone rubber	
O-rings	PTFE (Teflon)	
Gaskets		
Connections:	Inlets: 1/4" NPTM	Adapters Provided: * ball valve with stepped hose barb * pressure relief valve * 3/4" NPT to 11 mm hose barb
	Outlet: 3/4" NPTM	
Capacity:	KST 90: 750	KST 142: 1.5 L
Pressure:	Maximum differential pressure: 7 kg/cm ² (100 psi)	

Supplied with aluminum wrench (spanner) and 6 mm Allen wrench (hex key).

Filter holder size	90	142
Membrane filter size (mm)	90	142
Prefilter size (mm)	75	124
Filtration area (cm ²)	45	113

FILTRATION TIPS

- Prefilters can prolong a membrane filter's life by trapping particles which might otherwise clog the membrane's pores.
- PTFE O-rings and gaskets may become flattened with use under pressure. Boil them in water for a few minutes to restore shape and thickness.
- The pressure relief valve must be replaced as a unit. Disassembly affects pressure calibration.

CLEANING AND MAINTENANCE

- Disassemble the entire unit:
 - Inspect screens for nicks or rough edges and check O-rings and gaskets for cracking and loss of elasticity.
 - Carefully remove O-rings with blunt-tipped forceps.
 - Rotate (flip over) PTFE gasket (this minimizes flattening on the side in contact with the membrane).
- Clean all components with a standard, non-abrasive laboratory detergent:
 - Threaded connections may be cleaned with a stiff-bristled brush.
 - Sanitary connections, PTFE support screens, and interior surfaces may be cleaned with a sponge or non-abrasive cloth.
- Rinse with hot tap water followed by a final rinse with distilled or deionized water.
- To sterilize:
 - Assemble a completely dry filter holder with membrane as described in Assembly and Operation.
 - Attach tubing and clamps to holders. Tubing or hoses should be less than or equal to 3 feet long (1 meter) and must be completely dry.
 - Sealing clamps should only be finger-tight during assembly. Be sure vent relief valve (4) and ball valve (7) are open (handlers aligned with body) so that steam can penetrate the reservoir.
 - Wrap both inlet and outlet hoses with Kraft paper or similar steam permeable paper.
 - Autoclave the holder at 121°C (250°F) for the time listed in the table below. SLOW EXHAUST ONLY.

Filter holder size:	90	142
Time in minutes:	45	55

- After the holder has cooled to room temperature, be sure all connections are tight.

ASSEMBLY AND OPERATION

Before assembly: Wrap all threaded connections with PTFE tape.

1. Attach legs (15) to outlet plate (13) using sealing bolt (16) and locking washer (17). Attach outlet adapter (21) to outlet plate and connect tubing as needed (tubing not included).
2. Center underdrain support (12) and gasket (11) on outlet plate and place support screen (10) on top, smooth side up.
3. Using Tweezers (Pad) Miracle Tip Ends or other blunt-tipped forceps, center a membrane filter (MF) on the support screen.
4. Center a prefilter (optional, PF) on top of the membrane filter.
5. Be sure O-ring (9) is seated firmly in reservoir (8).
6. Center reservoir onto outlet plate (13), aligning holes over index screws. Slide bolt and wing nut assemblies into slots.
7. Tighten each bolt finger-tight, then work around the assembly, tightening each bolt one-quarter turn at a time.
8. To test for leaks, add a small amount of liquid through the inlet. Be sure the vent relief valve (4) is closed (lever perpendicular to body as shown in diagram) and slowly pressurize the unit with N₂ or similar inert gas. If needed, tighten inlet cap (1) with a wrench.
9. If connections are tight, vent the unit (lift the lever on the relief valve to align with the body). Fill the reservoir with fluid and retighten inlet cap (1).
10. Close the vent relief valve (4) and slowly pressurize the reservoir as described in step 8 above.

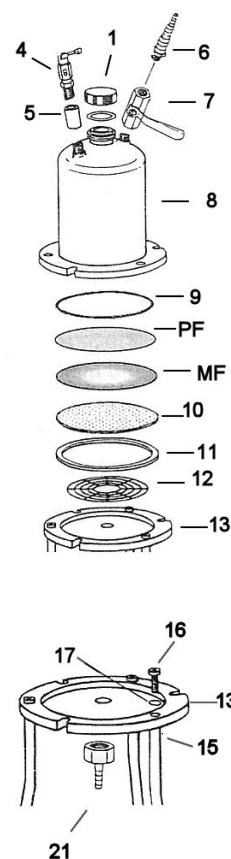

ORDERING GUIDE

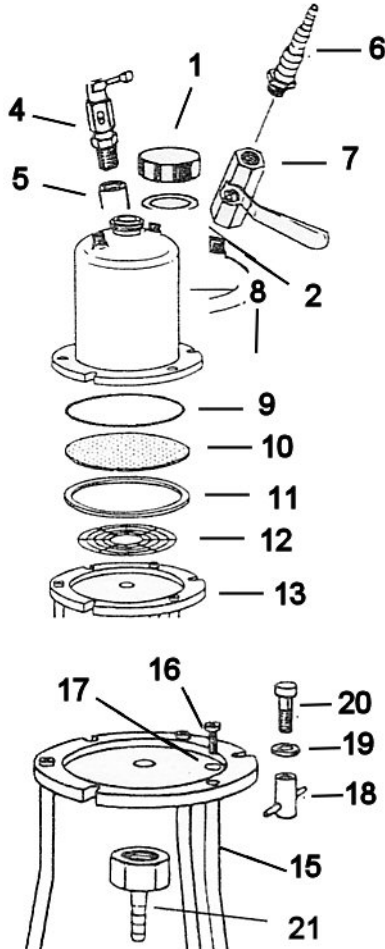

Inlet Assembly

#	Description	Material	90 mm	142 mm
1	Inlet cap		301610	302310
2	Inlet cap O-ring	silicone	301609	302309
4	Vent relief valve		301825	
5	Vent socket		302313	
6	Inlet adapter (3/4" NPTF to stepped hose barb)	304 SS 316 SS	351624 361624	
7	Valve	304 SS 316 SS	351625 361625	

Holder body and filter support system

#	Description	Material	90 mm	142 mm
8	Reservoir	304 SS 316 SS	351608 361708	302308 302408
9	O-ring	silicone	301705	301905
10	Support screen	PTFE coated SS	301804	302004
11	Gasket		301703	301903
12	Underdrain support	316 SS	301802	302002
13	Outlet plate	304 SS 316 SS	300801 300901	301901 302001

Sealing and support assemblies

#	Description	90 mm	142 mm
15	Leg	301719	301919
16	Sealing bolt (leg)	301718	
17	Locking washer (leg)	301720	
18	Wing-type nut	301914	
19	Sealing washer	301916	
20	Wing-type bolt	301915	
21	Outlet adapter (NPT to hose barb)	300817	300917

Accessories and alternate O-rings

#	Description	Material	90 mm	142 mm
2	Inlet cap O-ring	FEP-encapsulated silicone Viton	302328 302327	
9	O-ring	FEP-encapsulated silicone Viton	301706 301707	301906 301907
-	Back pressure support screen	304 SS 316 SS	301726 301728	301926 301928
-		PTFE coated 304 SS PTFE coated 316 SS	301727 301729	301927 301929
-	Allen wrench (hex key) 6 mm		301721	
-	Spanner (wrench) 142 mm		301922	