

STERLITECH

C o r p o r a t i o n

SEPA CF CELL ASSEMBLY & OPERATION MANUAL



CONTENTS

1. INTRODUCTION	1
2. SEPA CF CELL COMPONENTS.....	2
3. SEPA CF CELL ASSEMBLY	4
4. OPERATION OF THE SEPA CF CELL	11
5. SUPPLEMENTARY OPERATING INFORMATION	12
6. ACCESSORY AND SPARE PART ORDERING INFORMATION	13
7. RETURN MATERIAL AUTHORIZATION	14
8. WARRANTY	14
9. TECHNICAL ASSISTANCE	14
APPENDIX 1: SEPA CF CELL APPLICATIONS	15
APPENDIX 2: BENCH SCALE FILTRATION PRODUCTS.....	16

1. INTRODUCTION

The SEPA CF Cell is a laboratory-scale crossflow filtration unit that is designed to evaluate the performance of flat sheet membranes in a variety of applications. It simulates the flow dynamics of larger, commercially available membrane elements such as industrial spiral wound membrane elements. By using a combination of Stainless Steel (SS) shims, feed spacers, and membranes, users can vary the operating conditions and fluid dynamics over broad ranges.

Table 1 outlines the operational parameters and technical specifications of the Sepa CF Cell.

Prior to operating or servicing this device, this manual must be read and understood.

Table 1: Sepa CF Features and Technical Specification

Parameter	Description
Membrane Active Area	140 cm ² (22-inch ²)
Hold-Up Volume	70 ml (2.4 ounces)
Maximum Pressure: 316SS Cell Body	69 bar (1000 psig)
Maximum Temperature: 316SS Cell Body	177 °C (350 °F)
O-rings	Viton* (Other materials available)
pH Range	Membrane Dependent
Cross Flow Velocity	Variable
Dimensions	
Slot Depth	1.09 mm (0.075 inches)
Slot Width	95.3 mm (3.75 inches)

2. SEPA CF CELL COMPONENTS

Verify that the Sepa CF Cell was shipped complete, intact, and undamaged.

The complete Sepa CF Cell includes:

1. Stainless steel cell body: top and bottom

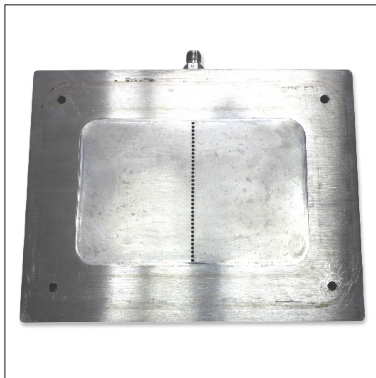

Cell Top



Cell Bottom

2. Anodized aluminum cell holder with piston and high pressure gauge



Cell Holder

3. Tubing and hardware kit, which includes:

a. Feed Spacers

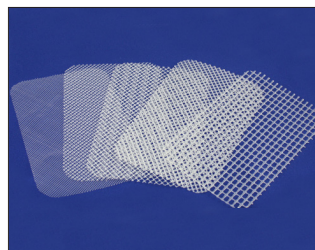

b. 1 pack of 5 permeate carriers

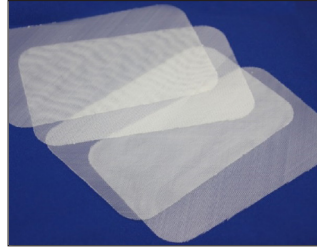

c. 1/4 diameter permeate tubing (91.4 cm (3 ft))

4. Concentrate control valve with high pressure gauge



Concentrate Control Valve

5. O-rings (2)

2.1 ADDITIONAL EQUIPMENT

The Sepa CF Cell also requires additional equipment to be operated, which are sold separately:

- Hydraulic hand pump to pressurize the cell holder
- Feed Pump
- Feed Tank
- Filtration membrane packs
- Assortments of shims and additional spacers

3. SEPA CF CELL ASSEMBLY

After verifying that all of the necessary components were shipped and present, you can begin the assembly of the Sepa CF Cell.

3.1 CELL BODY ASSEMBLY

The cell body consists of the cell top, membrane filter, feed spacer/ permeate carriers (optional), shims (optional), O-rings, and cell bottom. **Figure 1** illustrates a typical assembly of the cell body.

Figure 1: Typical Sepa CF Cell Body Assembly

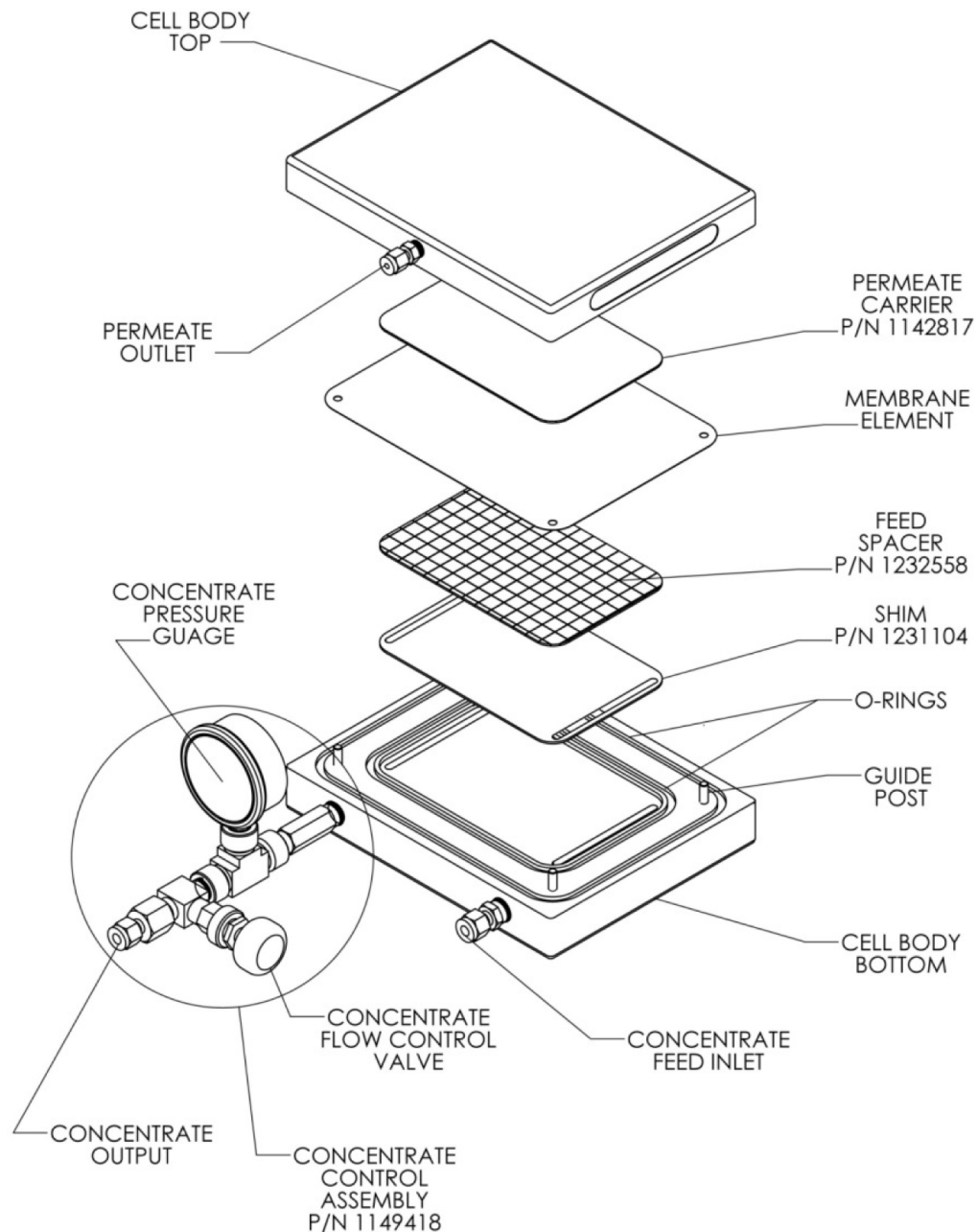

To assemble the Sepa CF Cell Body:

1. Connect the concentrate flow control valve to the cell bottom by wrapping PTFE tape around the valve's male NPT end and screwing it into the concentrate outlet port.

Note: The cell bottom is the half of the cell body that has the four alignment pins. The cell top has the holes to accept the alignment pins.

2. Install the O-rings into the grooves on the cell bottom and wet them with a small amount of water or the fluid to be processed.



Caution: Make sure the O-rings lie flat in the grooves of the cell bottom. Leaking may occur if the O-rings do not lie flat in the grooves. The O-rings will be cut or crushed when the system is operating if the O-rings are not installed correctly.

3. Place a shim, if needed, in the cavity inside of the inner O-ring.



4. Install the feed spacer into the central cavity, on top of the shim. The feed spacer must lie flat and be fully contained within the cavity.



Note: The feed spacer and the permeate carrier look similar and are cut in the same size. The permeate carrier is thinner and has a tight weave while the feed spacer has large gridding.

5. Place a piece of pre-cut membrane over the feed spacer using the four guideposts to hold the membrane in position. The membrane should be installed with the shiny (or active) side down toward the feed spacer.



Note: If you are cutting your own membranes, the membrane's outer edge should fit between the inner and outer O-rings in the cell body to prevent leakage.

6. Wet the permeate carrier with water or the fluid to be processed and place it into the cavity in the cell top. The surface tension caused by wetting the carrier will keep it in place.



7. Complete the assembly of the cell body by placing the cell top onto the cell bottom. The alignment holes should fit snugly over the alignment pins in the cell bottom.



8. Once the cell body is assembled and the quick release connector is installed into the cell holder (See *Cell Holder Assembly below*), insert the cell body into the cell holder until it rests against the two stops in the cell holder.



Caution: The Cell Body is very heavy: 14.5 kg (32 lbs).

3.2 CELL HOLDER ASSEMBLY

The cell holder is filled with Mobil DTE 20 Series Hydraulic Oil to operate the hydraulic piston. Before using the SEPA CF Cell for the first time, the brass quick release connector must be installed into the cell holder.

To install the quick release connector into the cell holder:

1. Wrap PTFE tape clockwise around the threads of the brass fitting while the open end is facing you.
2. Move the cell holder into a vertical position with the shipping plug and/or pressure gauge facing upward.*
3. Carefully remove the shipping plug in the hydraulic port of the cell holder.
4. Place the brass quick release connector into the hydraulic port.
5. Tighten the brass fitting with an open ended wrench (1" wrench is suggested).

* **Caution:** Attempting to install the brass quick release connector with the cell in the wrong position will cause the hydraulic fluid to spill.

3.3 SEPA CF CELL CONNECTIONS AND PARTS

Figure 2: Example Sepa CF Flow Diagram

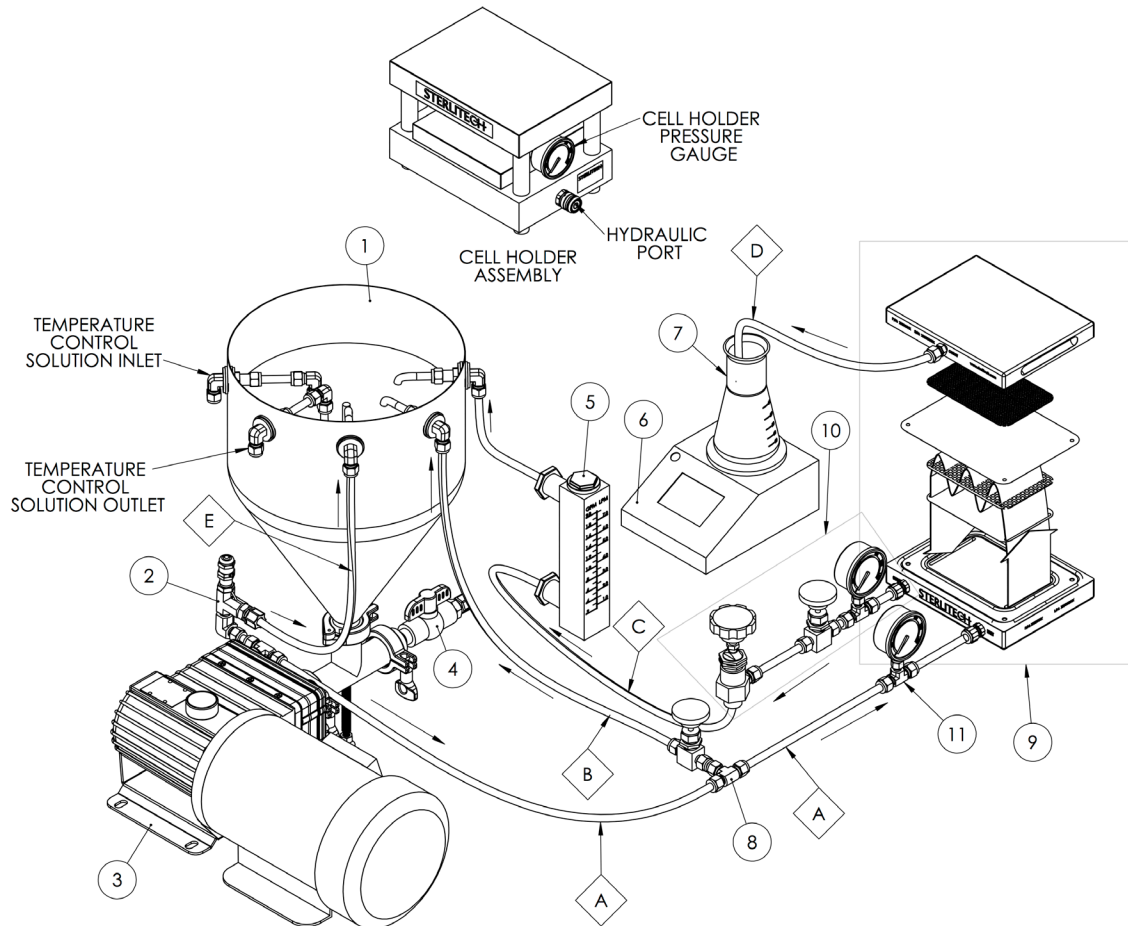

SEPA CF FLOW DIAGRAM	
ITEM NO.	PART DESCRIPTION
1	CONICAL FEED TANK
2	PRESSURE RELIEF VALVE
3	MOTOR & PUMP ASSEMBLY
4	DRAIN VALVE
5	FLOW METER
6	SCALE FOR MEASURING PERMEATE FLUX
7	PERMEATE COLLECTOR
8	BY-PASS NEEDLE VALVE WITH 3/8" "T" TUBE FITTING
9	SEPA CF CELL ASSEMBLY
10	CONCENTRATE CONTROL VALVE ASSEMBLY (0-1000 psi)
11	FEED PRESSURE GAUGE
A	3/8" HIGH PRESSURE FLEX OR RIGID TUBING, FEED LINE
B	3/8" LOW PRESSURE TUBING, BY-PASS
C	3/8" LOW PRESSURE TUBING, RETURN LINE
D	1/4" LOW PRESSURE TUBING, PERMEATE OUTPUT LINE
E	3/8" LOW PRESSURE TUBING



Figure 2 shows typical plumbing connections that need to be made for the operation of the SEPA CF Cell. The configuration can change slightly depending on the objectives of the user. In general, the connections to be made are:

1. Hydraulic pressure source to the cell holder
2. Feed vessel to the inlet pump
3. Pump outlet to the feed inlet of the cell body
4. Concentrate flow control valve to the feed vessel
5. Permeate outlet to the permeate collection vessel

Figure 2 also lists the additional components that are necessary to operate the SEPA CF cell. These components are sold separately and can be found in the Membrane/Process Development section of the Sterlitech website (<http://www.sterlitech.com/membrane-process-development.html>). The final assembly of the crossflow system will vary with the feed vessels, pumps, and tubing used.

To connect the hydraulic pressure source to the cell holder:

1. Push the quick release fitting of the hose of the hydraulic pressure source (hydraulic pump) against the quick release fitting installed into the cell holder. The outer collar of the female fitting will extend about 3.2 mm (1/8").
2. Rotate the collar on the female fitting 1/4 turn so the notch and the groove do not line up.
3. Pressurize the cell holder using the handle on the hydraulic pump up to 1000 psi.

To disconnect the hydraulic pressure source to the cell holder:

1. Release all hydraulic pressure in the system (by opening the release valve on the hand pump).

Caution: *Do not disconnect the hydraulic pressure source from the cell holder while the system is pressurized.*

2. Turn the collar on the female fitting until the notch and the groove line and push the collar to separate the fittings. Connect a length of 1/4" nylon tubing to the permeate outlet using the polypropylene fitting provided.
3. Insert the free end of the tubing into the permeate collection vessel. Ensure that all connections are snug.
4. Connect the 3/8" nylon tubing from the outlet of the feed pump to the inlet of the feed tank.

4. OPERATION OF THE SEPA CF CELL

Once the SEPA CF Cell has been assembled and connected to a feed system, it can be used in variety of applications that includes reverse osmosis, ultrafiltration, nanofiltration, and microfiltration.

To operate the Sepa CF Cell:

1. Set the feed pressure less than or equal to the piston pressure on the cell holder/cell body and turn the feed flow pump on.

***Note:** A good starting point may be to set the system at 1.7 bar (25 psig) pressure for ultrafiltration, 17.2 bar (250 psig) for reverse osmosis, and 2–3 Lpm (0.5–0.8 gpm) concentrate flow. If this does not produce the desired results then the parameters can easily be adjusted and different membranes can be used.*

2. Verify the feed pressure by comparing the reading on the piston cell holder pressure gauge to the reading on the concentrate pressure gauge.
3. Adjust the concentrate flow control valve to obtain the desired pressure and flow. Experimentation enables you to determine the optimum settings for pressure, flow rate, and shim/spacer combination to use on the chosen membrane and the fluid being processed.

To replace a membrane filter:

1. Turn the pumps OFF.
2. Turn the pressure relief valve knob on the hydraulic pump counterclockwise to release the hydraulic pressure in the system.
3. Slide the cell out of the cell holder.
4. Separate the cell body top from the cell bottom.
5. Remove the membrane.
6. Install the new membrane (and, if necessary, spacers/permeate carrier).
7. Reassemble the cell top and bottom.
8. Insert the cell in the cell holder.
9. Pressurize the cell holder to 1000 psi using the hand pump.
10. Turn the flow pumps on.

5. SUPPLEMENTARY OPERATING INFORMATION

5.1 MEMBRANE PERFORMANCE RESULTS

Spiral wound membranes containing mesh spacers are usually operated with a fluid velocity across the membrane surface of 0.1–0.5 m/sec (0.3–1.6 ft/sec). Higher velocities in membranes may lead to excessive pressure differential across the membrane and possible damage. Hollow fiber membranes, tubular membranes, and membranes with tubular spacers may be operated at higher velocities, but this may not contribute to a more effective operation.

5.2 MEMBRANE PERFORMANCE

Other parameters such as viscosity, pressure, and suspended solids may also affect performance/operation. Experimentation with the SEPA CF Cell can help predict the best operating parameters. If your pump is delivering too much flow, a portion of the flow can be diverted back to the feed container before entering the feed inlet of the cell body. This requires installation of an optional bypass valve and fitting on the pump outlet (**Figure 2, #4**), which is not supplied with the system.

5.3 TEMPERATURE LIMITS

The membranes, feed spacer, permeate, O-rings, and cell body materials construction dictate the maximum operating temperatures.

Table 2: Upper Temperature Limits

Component	Maximum Temperature
316 SS Cell	177 °C (350 °F)
Membrane Elements	Variable
Feed Spacer (PP)	82 °C (180 °F)
Permeate Carrier (PP)	82 °C (180 °F)
O-rings	
Viton	200° C (400° F)
EPDM	150° C (300° F)

Autoclaving the 316SS cell body is acceptable, recognizing the temperature limitation of 82°C (180°F) on the membrane, feed spacer, and permeate carrier. The cell holder should never be autoclaved because it does not come into contact with the process fluid.

5.4 MEMBRANE CLEANING

The SEPA CF Cell can be cleaned easily after the membrane is removed. However, you may wish to simulate the actual cleaning conditions of Cleaning-In-Place (CIP) in larger systems with spiral-wound or tubular membranes. This can be done with CIP. Clean-In-Place chemically cleans without removing the membrane to mechanically scrub the unit.

During CIP, cleaning solutions are re-circulated and, in some cases, allowed to sit for a period of time within the cell body. In some cases, the feed pump can be used to re-circulate the cleaning solutions.

6. ACCESSORY AND SPARE PART ORDERING INFORMATION

Accessories and spare parts for the Sepa CF Cell can be ordered by calling Sterlitech Corporation at 1-877-544-4420 or by visiting www.sterlitech.com.

Table 3: Accessory and Spare Part Ordering Information

Product	Shipping Weight	Ordering Number
Sepa CF Cell, for operation to 69 bar (1000 psig)	39 kg (86 lbs)	1230060
Hydraulic Hand Pump Kit	5 kg (11 lbs)	1230086
Feed Flow Pump	Contact Sterlitech	Contact Sterlitech
Accessories		
Permeate Carrier Pack (PP)	0.5 kg (1 lb)	1142817
17 mil Feed Spacer (PP, 5/pack)	0.5 kg (1 lb)	1142816
31 mil Feed Spacer (PP, 5/pack)	0.5 kg (1 lb)	1142818
47 mil Feed Spacer (PP, 5/pack)	0.5 kg (1 lb)	1143763
47 mil Parallel Feed Spacer (PP, 5/pack)	0.5 kg (1 lb)	1142814
65 mil Feed Spacer (PP, 5/pack)	0.5 kg (1 lb)	1142819
Feed Spacer Assortment Pack (PP): 17, 31, 47, and 65 mil¹	0.5 kg (1 lb)	1232558
Shims (12 total/pack):		
<ul style="list-style-type: none"> • 4 of 2 mil • 4 of 5 mil • 2 of 10 mil • 1 of 15 mil • 1 of 25 mil 	0.5 kg (1 lb)	1231104
Spare Parts		
Membrane Packs	Contact Sterlitech	Contact Sterlitech
Viton O-rings	28 g (1 oz)	1143205
Aluminum Cell Holder	21 kg (46 lbs)	1230029
Concentrate Control Valve	0.9 kg (2 lbs)	1149418
Sepa Cell Body	14.5 kg (32 lbs)	1230064

¹Other materials and sizes are available. Contact Sterlitech Corporation for more information.

7. RETURN MATERIAL AUTHORIZATION

If materials are to be returned to Sterlitech for repair, evaluation, or warranty consideration, a Return Material Authorization (RMA) number and form must be obtained from Sterlitech prior to the return. Contact Sterlitech's Customer Service Department for these forms.

The form must be completed and returned with the material. Be sure to include a complete, detailed written reason for the return. Also, include serial numbers, installation and removal dates, and any other pertinent information that is available. Sepa FO Cells have a serial number imprinted on the cell bottom.

Indicate the proposed disposition of the material, and reference the RMA number on all packages or cartons. All material must be shipped to Sterlitech with freight prepared by the customer.

8. WARRANTY

The following is made in lieu of all other warranties expressed or implied. Sterlitech Corporation guarantees equipment to be free from defects in material and workmanship when operated in accordance with written instructions for a period of one year from receipt. Parts not manufactured by Sterlitech are covered by their manufacturer's warranties, which are normally for one year.

Manufacturers and Seller's only obligation shall be to issue credit against the purchase or replacement of equipment proved to be defective in material or workmanship. Neither manufacturer nor seller shall be liable for any injury, loss or damage, direct or indirect, special or consequential, arising out of the use of, misuse, or the inability to use such product.

The information contained herein is based on technical data and tests, which we believe to be reliable, and is intended for use by persons having technical skill at their discretion and risk. Since conditions of use are outside Sterlitech's control, we can assume no liability whatsoever for results obtained or damages incurred through the application of the data presented.

This information is not intended as a license to operate under, or a recommendation to infringe upon, any patent of Sterlitech or others covering any material or use.

The foregoing may not be altered except by a written agreement signed by officers of the manufacturer.

9. TECHNICAL ASSISTANCE

Please contact us if you have any questions or technical inquiries about our products by calling Sterlitech Corporation at 1-877-544-4420 or by visiting www.sterlitech.com.

APPENDIX 1: SEPA CF CELL APPLICATIONS

The following studies utilized the SEPA CF Cell in their method and are listed here to illustrate the potential applications for the SEPA CF. These studies are good references for understanding the operation of the SEPA CF Cell.

APPLICATION	STUDY CITATION
Reverse Osmosis (Desalination)	Sachit, Dawood Eisa. "Analysis of reverse osmosis membrane performance during desalination of simulated brackish surface waters." <i>Journal of Membrane Science</i> . 453. (2014): 136-154.
Forward Osmosis and Low Pressure Reverse Osmosis	Yangali-Quintanilla, Victor, Zhenyu Li, et al. "Indirect desalination of Red Sea water with forward osmosis and low pressure reverse osmosis for water reuse." <i>Desalination</i> . 280. (2011): 160-166.
Ultrafiltration (Food Processing)	Post, Antonie, Hanna Sampels, et al. "A comparison of micellar casein and β -casein as sources of basic peptides through tryptic hydrolysis and their enrichment using two-stage ultrafiltration." <i>International Journal of Dairy Technology</i> . 65.4 (2012): 482-489.
Ultrafiltration and Nanofiltration (Protein Production)	Ranamukhaarachi, Sahan, Lena Meissner, et al. "Production of antioxidant soy protein hydrolysates by sequential ultrafiltration and nanofiltration." <i>Journal of Membrane Science</i> . 429. (2013): 81-87.
Membrane Development	Qadir, Ahmad. Development of new membranes for desalination pre-treatment. MA thesis. University of Illinois at Urbana-Champaign, 2011. Web. < https://www.ideals.illinois.edu/handle/2142/26369 >.

APPENDIX 2: STERLITECH BENCH SCALE FILTRATION PRODUCTS

Membrane & Process Development Product Families

	Discoverer	Innovator	Explorer	Developer	Investigator
Filter Holder	 HP4750(X)	 CF016	 CF042	 Sepa	 1812
Membrane Active Area	14.6 cm ² (2.26 in ²)	20.6 cm ² (3.2 in ²)	42 cm ² (6.5 in ²)	140 cm ² (24 in ²)	0.27-0.46 m ² (3-5 ft ²)
Typical Permeate Flow Rate (per Cell)	1.5-15 mL/min	1-10 mL/min	2-20 mL/min	7-70 mL/min	350-2,300 mL/min
System Capacity	0.7-7 L/day (0.2-2 GPD)	1.5-15 L/day (0.4-4 GPD)	3-30 L/day (0.5-5 GPD)	10-100 L/day (2.6-26 GPD)	194-1,940 L/day (51-510 GPD)
Min. Batch Volume (per Cell)	300 mL	3.7 L (1 gal)	3.7 L (1 gal)	3.7 L (1 gal)	15 L (4 gal)
Max. Pump Capacity	N/A	6.8 LPM (76 bar) 1.8 GPM (1,100 psi)	6.8 LPM (76 bar) 1.8 GPM (1,100 psi)	6.8 LPM (76 bar) 1.8 GPM (1,100 psi)	6.8-38 LPM (76 bar) 1.8-10 GPM (1,100 psi)
Cell Material	SS316, Hastelloy™	PTFE, Delrin, Acrylic, SS316, Hastelloy™	PTFE, Delrin, Acrylic, SS316, Hastelloy™	Acrylic, SS316, Hastelloy™	SS316
Max. Operating Pressure	HP4750: 69 bar (1,000 psi) HP4750X: 172 bar (2,500 psi)	PTFE/Acrylic: 27.6 bar (400 psi) Delrin/SS316/Hastelloy™: 69 bar (1,000 psi)	PTFE/Acrylic: 27.6 bar (400 psi) Delrin/SS316/Hastelloy™: 69 bar (1,000 psi)	Acrylic: 27.6 bar (400 psi) SS316/Hastelloy™: 69 bar (1,000 psi)	41.4 bar (600 psi)
Filtration Mode(s)	Dead-End Stirred Cell	Cross Flow, Forward Osmosis	Cross Flow, Forward Osmosis	Cross Flow, Forward Osmosis	Cross Flow

NOTES:

Founded in 2001 in Kent, WA, Sterlitech Corporation manufactures and markets filtration-focused laboratory products to a broad spectrum of scientific and industrial sectors. Its line of flat sheet membranes and tangential flow cells deliver industry-leading performance and reliable results. Configured for reverse osmosis, nanofiltration, ultrafiltration, and microfiltration applications, Sterlitech's bench scale test equipment provides the versatility required to innovate.

Sterlitech's comprehensive line of products is supported by the expertise of its technical specialists who can assist with application-specific product selection, and provide customized solutions where necessary. Unique problem-solving approaches, flexibility, and consistent quality have made Sterlitech Corporation a renowned global provider of filtration products and equipment.

General Corporate Information

Sterlitech Corporation

22027 70th Avenue S
Kent, WA 98032-1911 USA
Tel: 877-544-4420 or 1-253-437-0844
Fax: 1-253-437-0845

info@sterlitech.com

Sales Inquiries
sales@sterlitech.com

Accounts Payable
AP@sterlitech.com

Accounts Receivable
AR@sterlitech.com

Press Inquiries
PR@sterlitech.com

© 2018 Sterlitech Corporation
22027 70th Ave. S
Kent, WA 98032-1911 USA
Phone: (253) 437-0844
Fax: (253) 437-0845
Email: sales@sterlitech.com